

R/C CAR INERTIA MOTOR DYNO

Quick Start Guide

V1.0

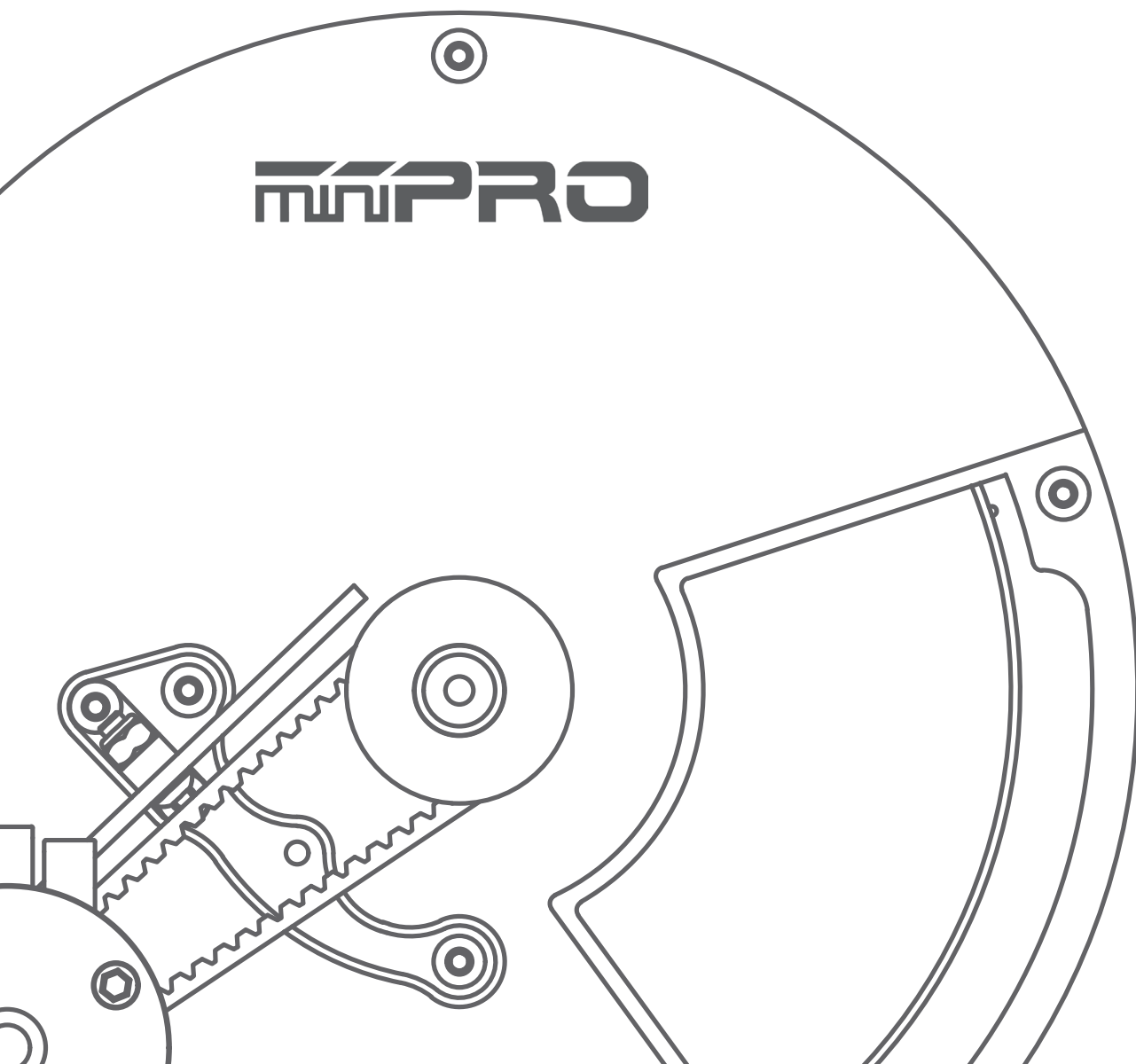

MMPRO

USING THIS GUIDE

Before Using the Dyno

This dyno is a high-quality motor analyzing tool intended for persons aged 18 years and older with previous experience building and operating RC cars, boats, airplanes, and drones. This is not a toy; it is a precision testing equipment. This dyno is not intended for use by beginners, inexperienced customers, or by children without direct supervision of a responsible, knowledgeable adult. If you do not fulfill these requirements, please return the kit in unused and unassembled form back to the shop where you have purchased it.

Before building and operating your dyno, YOU MUST read through all of the operating instructions and instruction manual and fully understand them to get the maximum enjoyment and prevent unnecessary damage. Read carefully and fully understand the instructions before beginning assembly. Contents of the box may differ from pictures. In line with our policy of continuous product development, the exact specifications of the dyno may vary without prior notice.

TOOLS REQUIRED

Allen: 1.5mm, 2.0mm

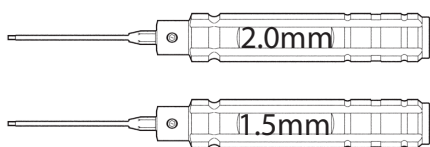

Phillip Screw Driver

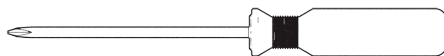

Soldering Iron

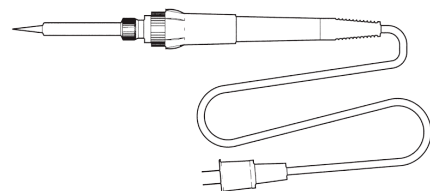

EQUIPMENT REQUIRED

Electric Motor

540/550 Motor

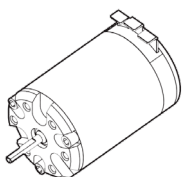

OR

Outrunner Motor

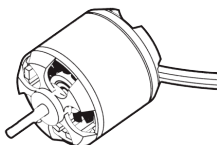

Electronic Speed Control (ESC)

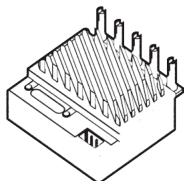

Battery

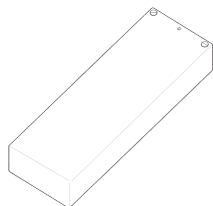

Throttle Controller

R/C Transmitter and Receiver



OR

Servo Tester

OR

ESC Controller Sensor*
(Sold by miniPRO)

* Additional USB port is required.

Windows PC



Operating System: 7, 8, or 10
(1) USB Port for Dyno

CONTENTS

Using this Manual.....	2
Before Using the Dyno	2
Tools Required.....	2
Equipment Required.....	2
Dyno Feature Highlights.....	6
Assemble the Dyno	7
Electronic Connections	8
(miniPRO) Volt. & Current Sensor.....	8
(Pololu) ESC Controller Sensor.....	9
Driver Installation.....	10
Dyno Driver for Windows	11
ESC Controller Sensor Driver.....	12
Software Installation	13

CONTENTS

Flywheel Change.....	14
Testing Motors.....	15
Manual Mode.....	15
Sequence Mode.....	16
Part List.....	17

DYNO FEATURE HIGHLIGHTS

This is a universal motor dynamometer (dyno) that is ready to test electric motors out of the box. Featuring an onboard electrical board equipped with an optical rpm sensor that measures motor speeds at up to 100,000 rpm. The board is also equipped with auxiliary ports for an external LCD screen, throttle controller, and different types of sensors for measuring voltage, current, and temperature.

Its interchangeable motor mounts and pulleys give the option to test 540, 550 and Outrunner motors. A balanced flywheel (inertia mass) is enclosed by a high grade aluminum 6061 cover to provide safety. The flywheel is replaceable, that means you are not limited to the same load when testing your motors.

This dyno is great tool for motor analysis, ESC (boost) adjustment, brushless sensor adjustment, gearing calculation, acceleration testing, kV measuring, voltage drop, current draw, power, and torque output analysis.

1. Front Cover

2. Belt

3. Flywheel Pulley

4. Belt Tensioner Bracket

5. Flywheel Window

6. Sliding Block

7. Base

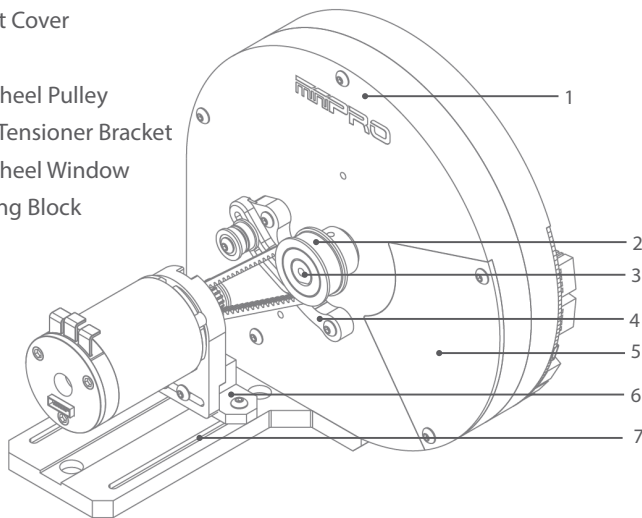

8. Belt Tensioner

9. Motor Holder*

10. Motor Pulley

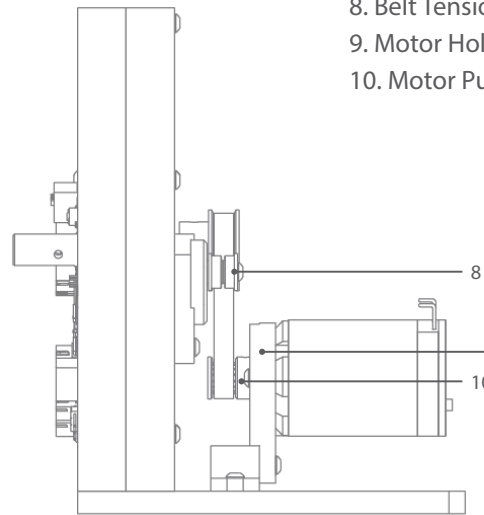

Outrunner

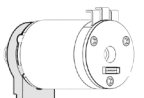

540/550

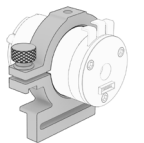

Quick Swap
OR
Custom Mount

11. Rear Cover

12. Reset

12. Flywheel

14. Electronic Board

15. Switches

16. LCD / UART Port

17. Temp. X Port

18. AUX Port

19. RPM Ext. Port

20. USB Micro Port

21. Flow Sensor Port

22. Temp. Port #1

23. Temp. Port #2

24. Temp. Port #3

25. Voltage and Current Sensor Port

26. SERVO / ESC Port *

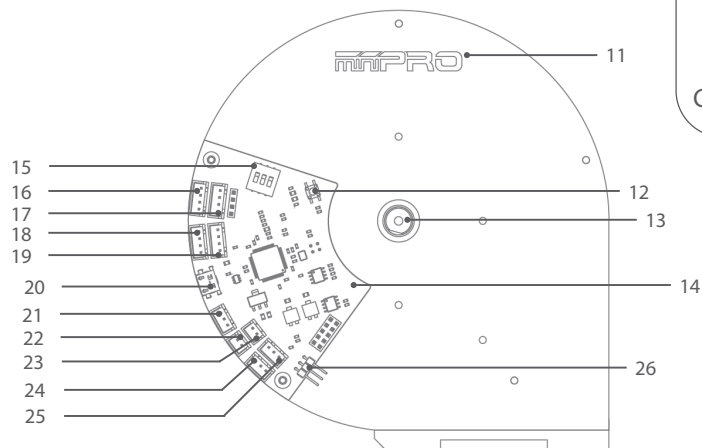

* May not be included in your kit. Please verify the included content in your purchased kit.

ASSEMBLE THE DYNO

The dyno its already been pre-assembled. All you need to do is install the base plate, mount the motor's belt and pulley.

1 Screw on the motor on the mount

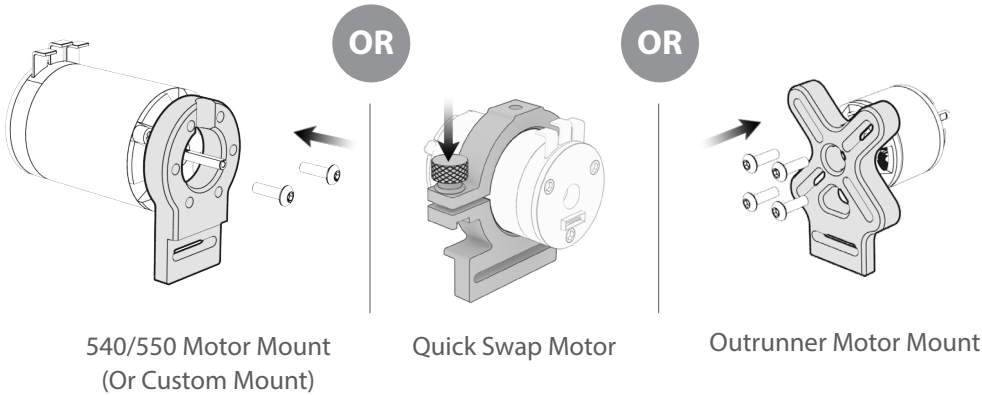

2 Install the Motor Pulley

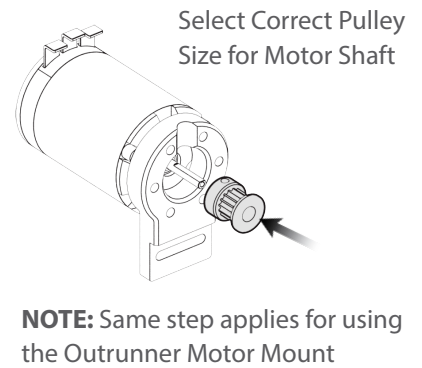

3 Install the Base

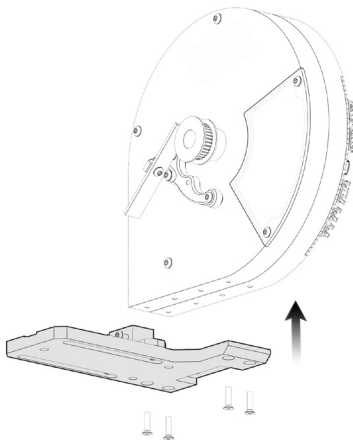

4 Attach the Dyno to a Baseboard

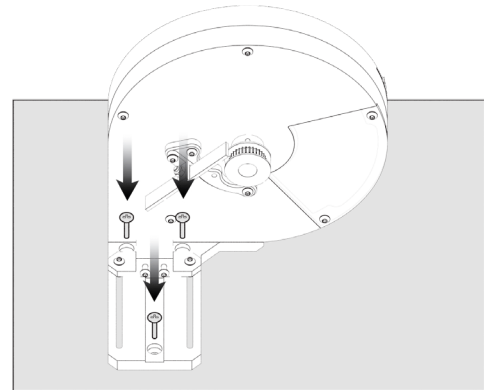

5 Mount the Motor

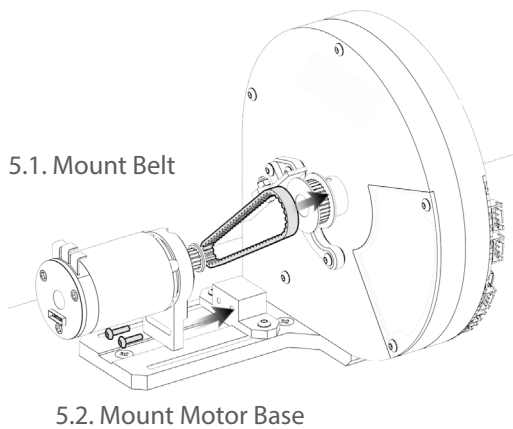

6 Adjust the Belt Tension and Position

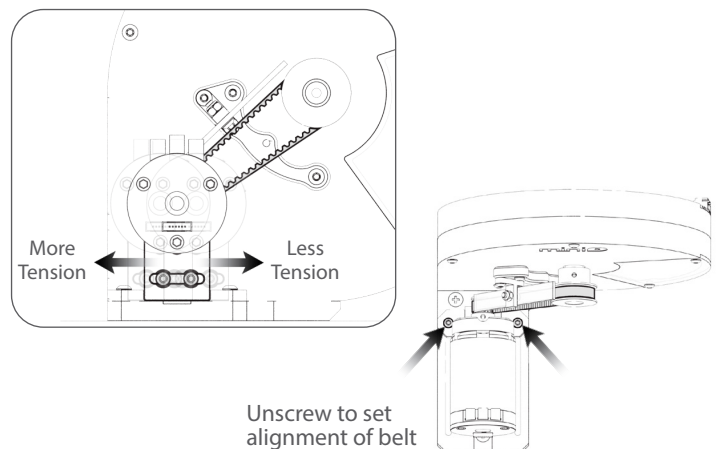

ELECTRONIC CONNECTIONS

miniPRO H1 Voltage and Current Sensor Connection

Voltage and Current Sensor Diagram

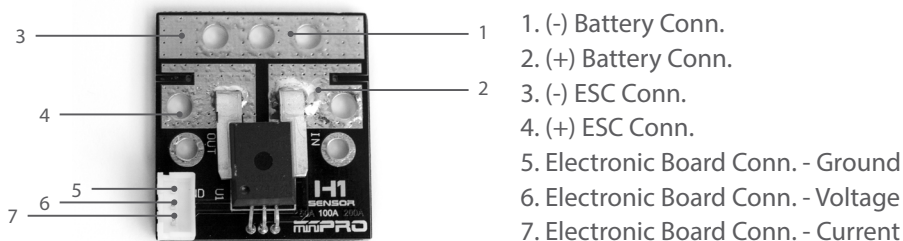

NOTE: This diagram applies to the 50A, 100A, 150A and 200A sensor.

1

Solder Wires or Connectors

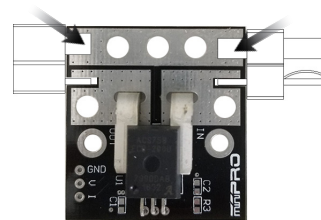

Solder the connectors of your preference OR 14 gauge wires. Try to keep the wires as short as possible to reduce the electrical losses

2

Connect Transmitter, Receiver, and ESC to the Motor

Please refer to the ESC, Transmitter, and Receiver manufacturers' instruction manual.

3

Connect Sensor

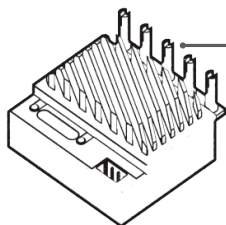

3.1. Connect the ESC's battery port to the sensor's ESC connector. See above sensor diagram for more information.

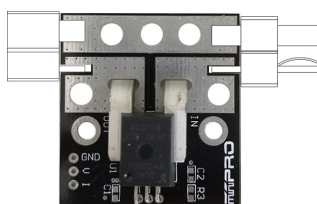

3.2. Connect the battery to the sensor's battery connector.

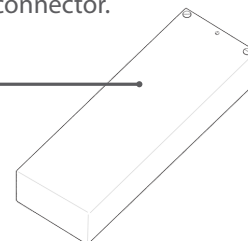

3.3. Turn ON the ESC and make sure it powers on. **If the sensor starts to overheat, disconnect the battery immediately.**

4

Connect Sensor to Electronic Board

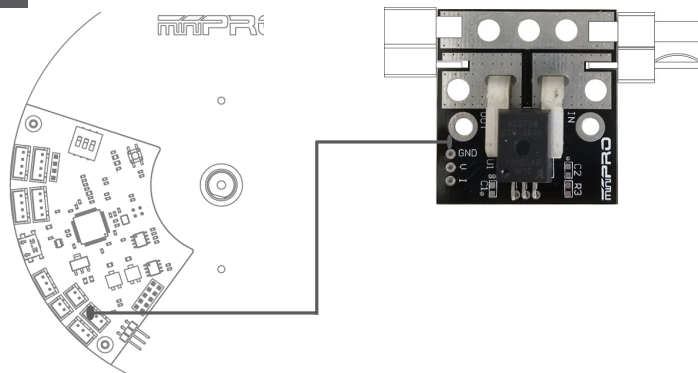

IMPORTANT: You must calibrate the sensor each time the dyno is powered.

Calibration Instructions:
Refer to the H1 Sensor user manual.

ESC Controller Sensor Connection

ESC Controller Diagram (External Board)

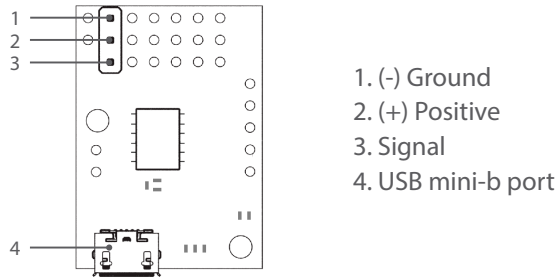

NOTE: This sensor its already been pre-programed to be used with the dyno.

1 Connect Sensor

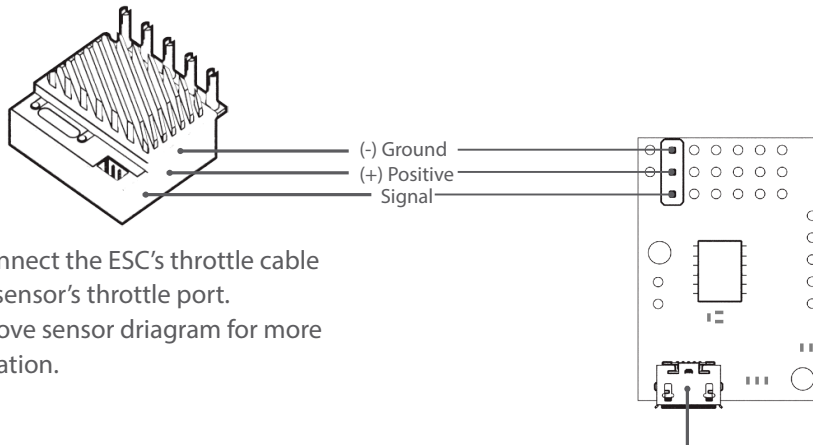

2.1. Connect the ESC's throttle cable to the sensor's throttle port. See above sensor driagram for more information.

2.2. Connect the sensor to the PC with a mini-b USB cable.

DRIVER INSTALLATION

Electronic Board Driver Installation for Windows 7 and 8

- 1** Download the driver, and connect the dyno to the pc using the micro-b USB cable.

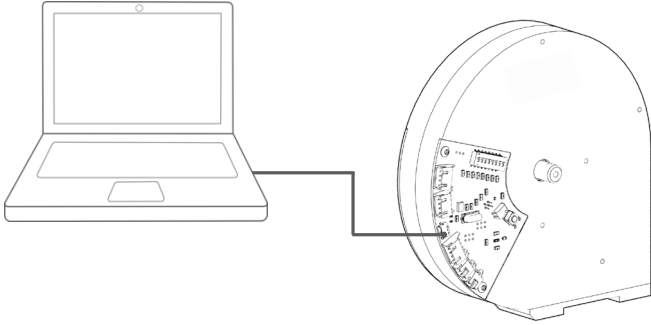

Go to --><http://minipro.wiki/downloads>

Download the latest driver and extract the driver to a new folder.

- 2** Open the "Device Manager"

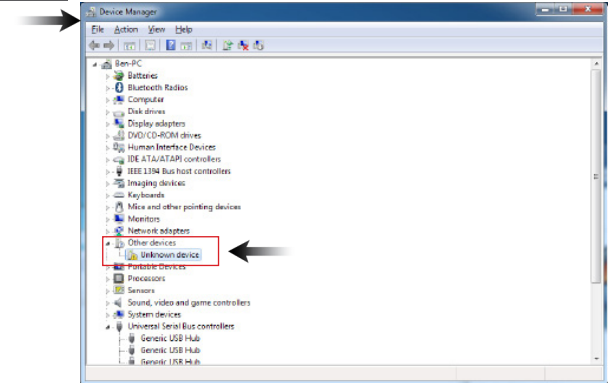

NOTE: When you plug the dyno, a new communication port should appear when the driver was installed successfully.

- 3** To open the "Device Manager"

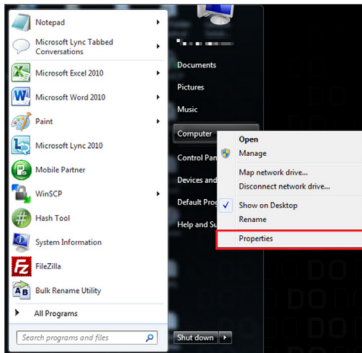

3.1. Go to --> right-click on Computer.

Click Properties

3.2. In the Properties window, click on Device Manager.



- 4** Select "Other Devices" and right click "Unknown device" and then select "Update Driver Software"

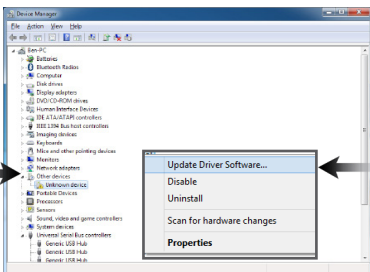

4.1. Select "Browse my computer..."

4.2. Select "Let me pick from a list."

4.3. Select "Have a disk" and locate the driver that was saved earlier.

Note: If "Other devices" is not available, then check the USB connection, or otherwise, It might be possible that the driver was already been installed by windows.

- 5** Take note of the new communication port created by the electronic board driver.

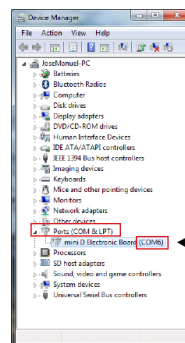

OR

If the driver was automatically installed, it might be available under "Ports."

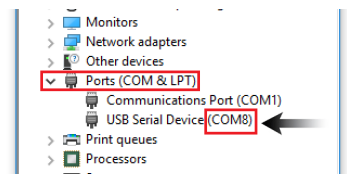

NOTE: The communication port is required to run the dyno. Above port number may differ from your pc.

Electronic Board Driver Verification for Windows 10

1 Connect the dyno to the pc using the micro-b USB cable.

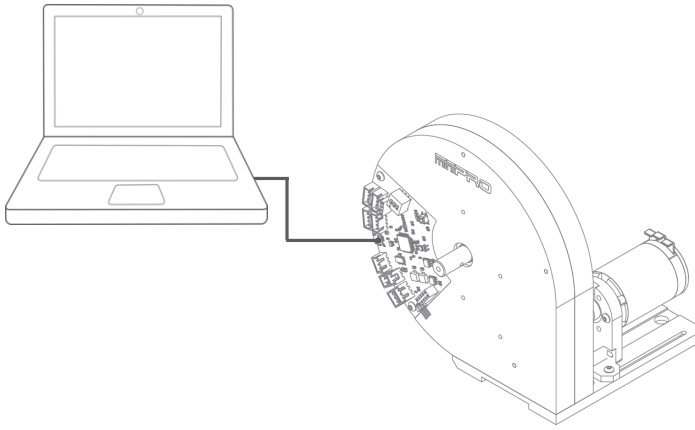

NOTE: It's not necessary to install the electronic board driver. (Windows 10 automatically installs the driver)

2 Verify the driver was automatically installed by opening the "Device Manager."

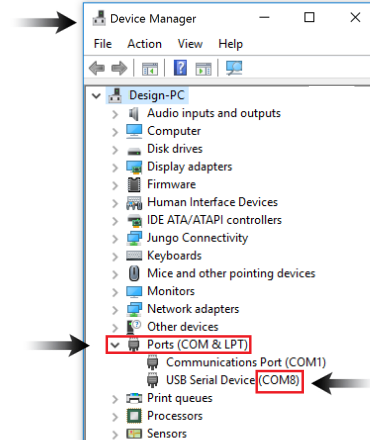

NOTE: When you plug the dyno, a new communication port should appear when the driver was installed successfully.

3 To open the device manager, right-click on the Windows Start Button, and click "Device Manager"

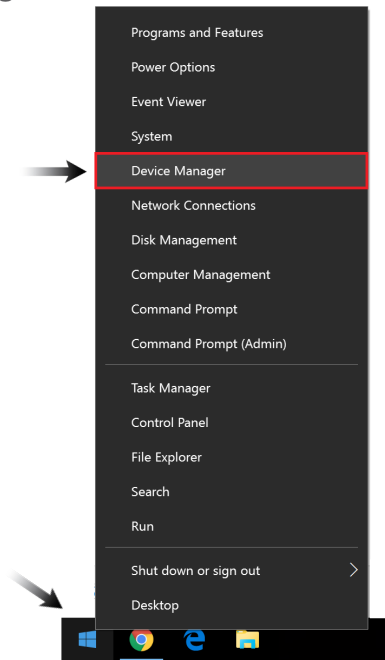

4 Take note of the new communication port created by the electronic board driver.

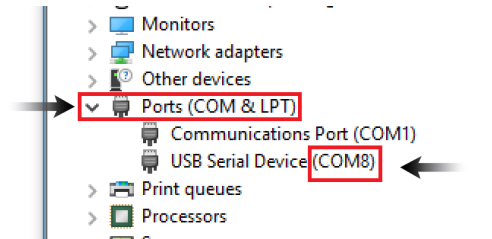

NOTE: The communication port is required to run the dyno. Above port number may differ from your pc.

ESC Controller Sensor Driver Installation

1 Connect the sensor to the pc using the mini-b USB cable.



Go to --><http://support.miniprousa.com/095696-Drivers>
Download the latest driver and extract the driver to a new folder.

2 Run setup.exe.
The installer will guide you through the steps required to install the sensor.

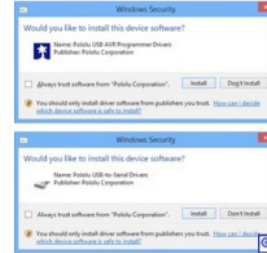

During the installation, Windows will ask you if you want to install the drivers. Click "Install" (Windows Vista, Windows 7, and later).

3 After installing the drivers and plugging the ESC Controller Sensor in via USB, if you go to your computer's Device Manager, you should see three entries for the Sensor that look like what is shown below:

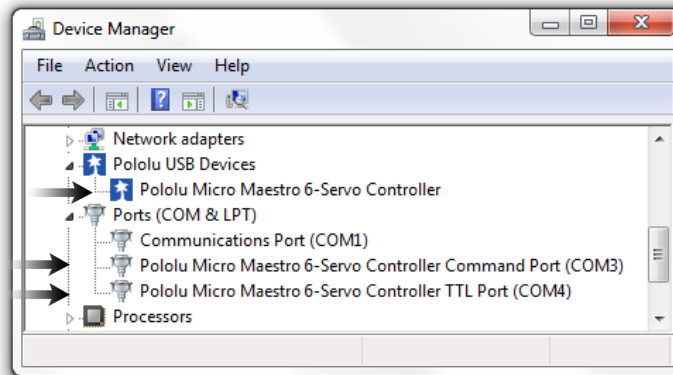

NOTE: After you completed a pololu driver installation, the two COM ports might not rename automatically. You must right click the COM port and select "Update Driver" on each one, or the sensor won't work properly.

4 Done!
If you have any questions, please go to support.miniprousa.com and submit a ticket.

SOFTWARE INSTALLATION

Install the Software

1 Download Software

Go to--> <http://support.miniprousa.com>
(Downloads->Softwares->Dyno Softwares)
Next, download the latest software and start the installation.

NOTE: You need a serial number to install the application.

2 Read the Warning Notes and click "Next" if you agree.

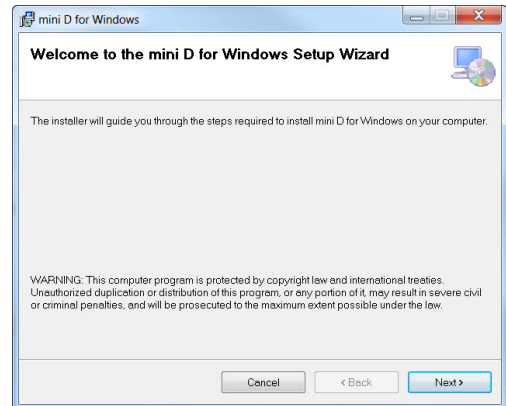

3 Select the location folder where "mini D" will be installed, and then select the person who can use the application. Click "Next."

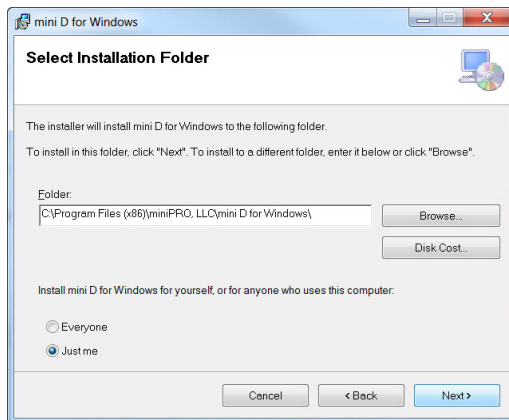

4 Confirm that you want to install "mini D" on your computer, and click "Next" to continue.

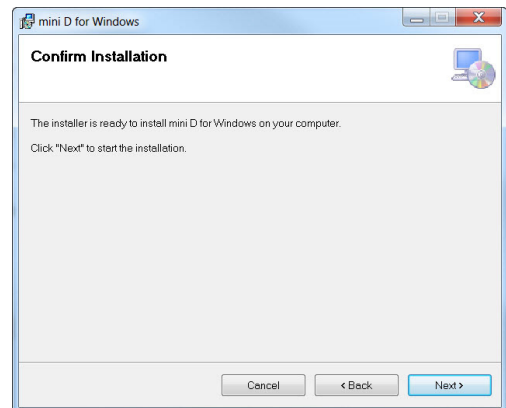

5 Wait a few minutes while "mini D" installs on your computer.

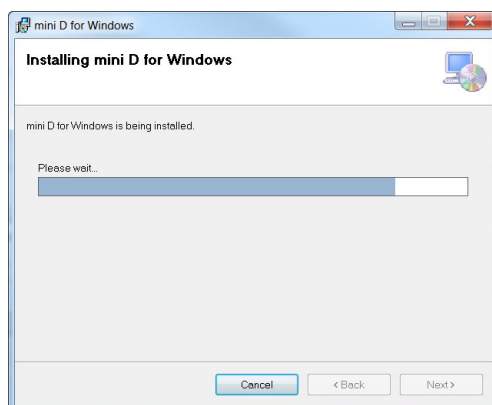

6 When installation finishes, click "Close" and you have successfully installed "Mini D" for Windows.

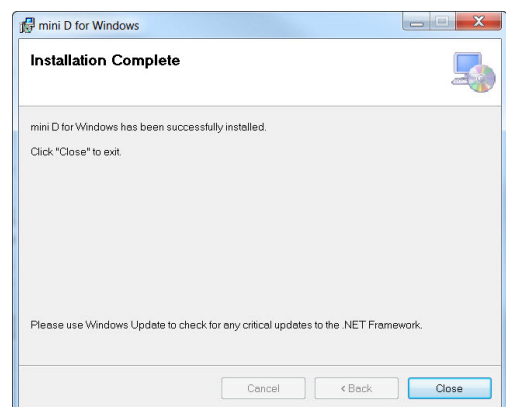

FLYWHEEL CHANGE

Flywheel Replacement Instructions

1 Unscrew on the Motor

5.2. Remove the belt

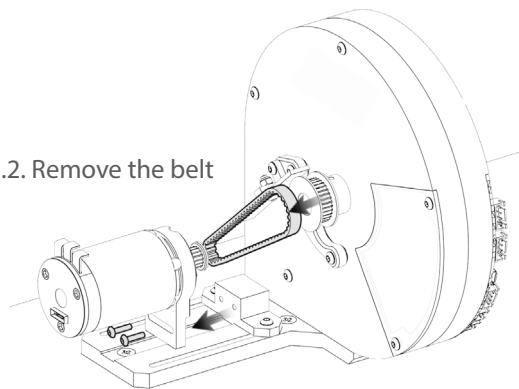

5.1. Unscrew the motor holder

2 Unscrew the Dyno from the Baseboard

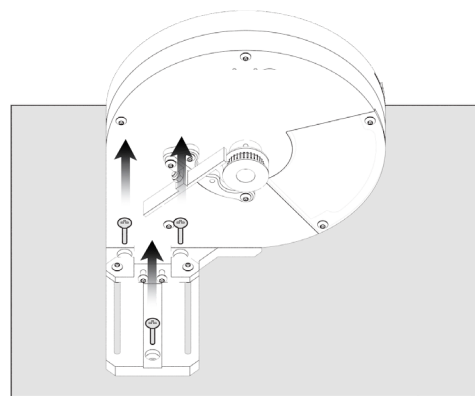

3 Remove the Base

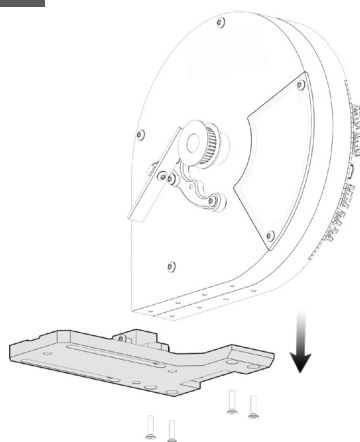

4 Remove the Flywheel Pulley and Front Cover

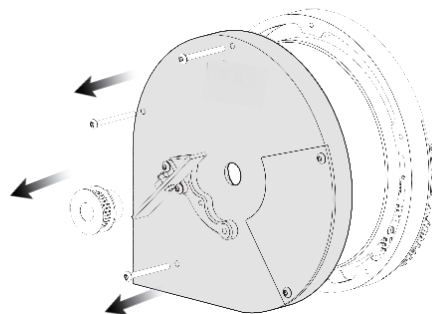

Note: Need to remove the pulley first before removing the front cover.

5 Replace the Flywheel

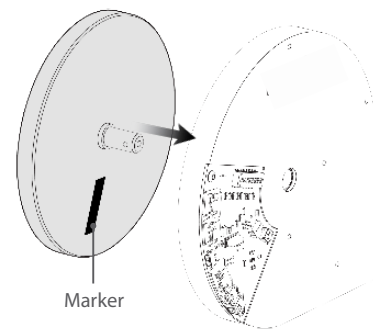

Note: Make sure the marker (black tape) is facing the electronic board.

6 Install the Flywheel Pulley and Cover

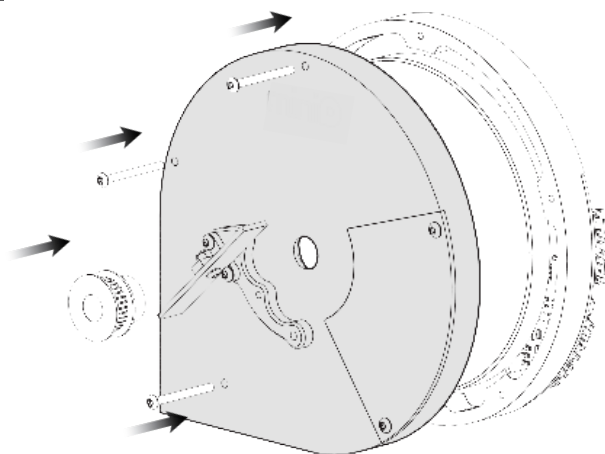

7 Assemble the Dyno

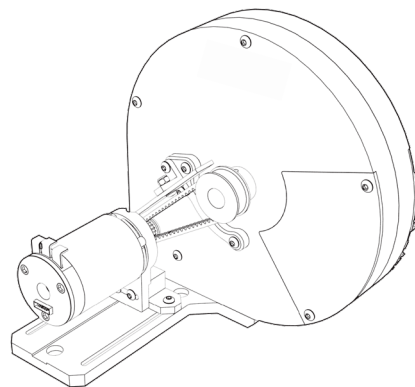

Note: For assembly information please go-to page no. 7 on the instruction manual.

TESTING MOTORS

Manual Mode (Ex. Using R/C Transmitter or Servo Tester)

1 Connect the dyno to the PC using the micro USB cable.

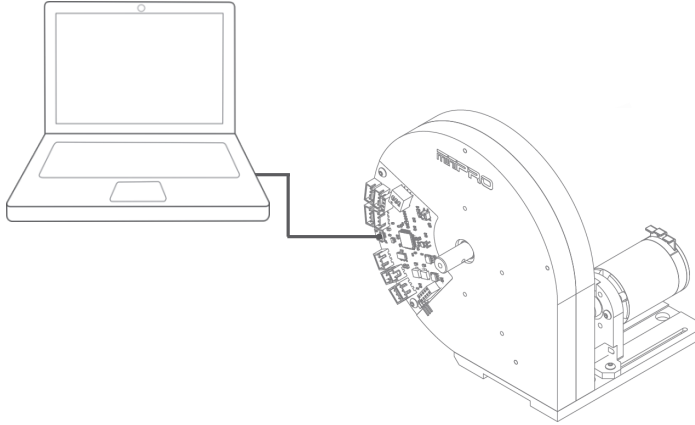

2 Open the Application, and select the click "Connect."



Select the correct COM Port from the drop box menu.

NOTE: (2) two USB connection ports are required.

3 Move the motor with your transmitter or servo tester and try to keep a constant RPM.

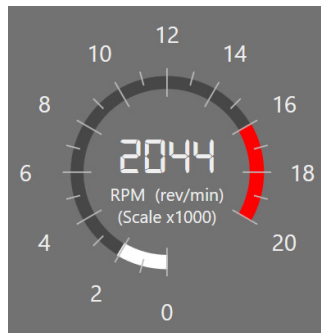
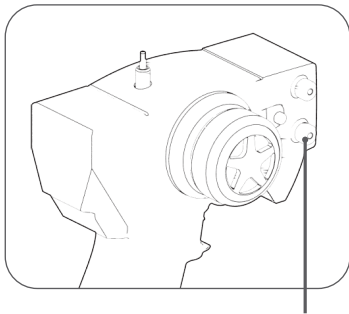

NOTE: By adjusting the throttle trim you can keep a constant RPM.

4 Go-to the "Configure Test" tab and select "No" under the under "Enable Servo/ESC Sequence."

4.1 Go-to "Run Test" tab and click on "Start Test" button.

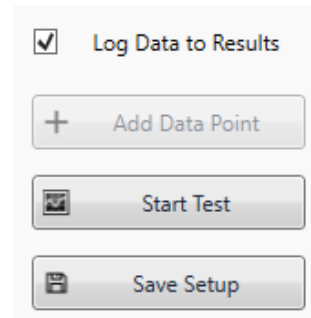

5 When you reach maximum RPM, click "Stop" or press ESC key

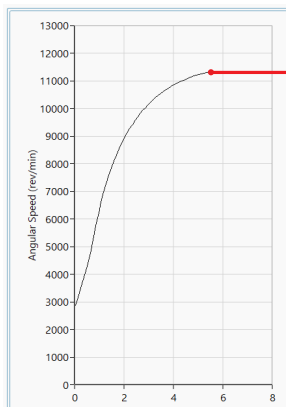

Max. RPM as soon torque and power reaches zero.

5.1. Once the test is complete. Go-to "Test Results" tab to review your test results.

5.2 You can save, print and export the test results.

5.3 Done!"Stop" button or ESC key.

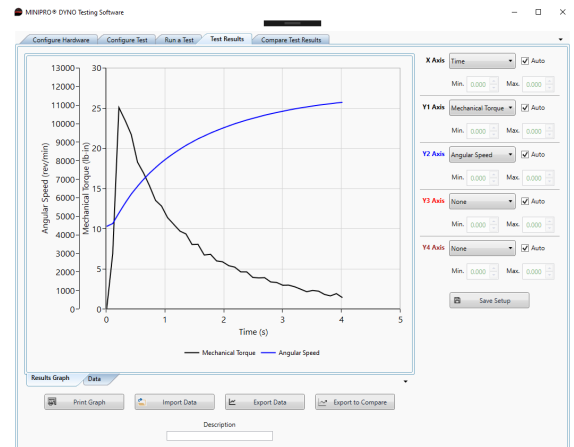

Sequence Mode (Ex. Using Th. Controller Sensor for Servo and ESC)

1 Connect the dyno to the PC using the micro-b USB cable, and connect the Throttle Controller Sensor to the PC using the mini-b USB cable.

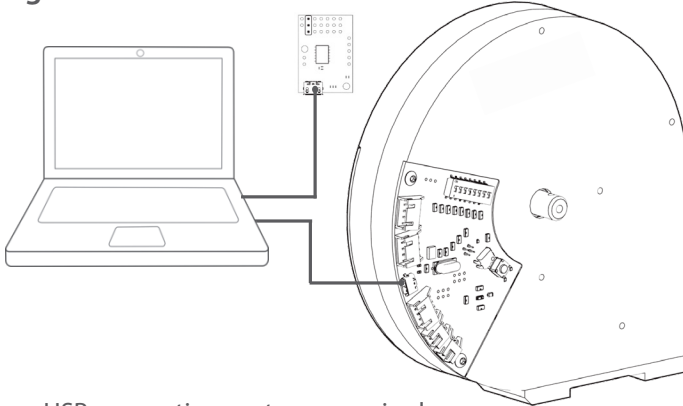

NOTE: (2) two USB connection ports are required.

2 Open the Application, and select the click "Connect."



Select the correct COM Port from the drop box menu.

3A Calibrate Throttle for ESC

- 3.1. If you already performed the calibration; please ignore this step.
- 3.2 Go-to "Configure Test" tab and select YES under "Enable Servo/ESC Sequence"
- 3.3. Set your ESC to Calibration Mode; and click once the "Neutral, Throttle, and Brake buttons when your ESC's requires it.
- 3.3. Click "Save Throttle Settings."

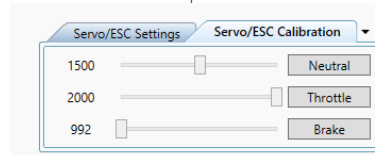

3B Calibrate Throttle for Servo

- 3.1. If you already performed the calibration; please ignore this step.
- 3.2 Go-to "Configure Test" tab and select YES under "Enable Servo/ESC Sequence"
- 3.3. Set your Servo to "Neutral, Throttle, and Brake by draggin each slider to the desired position.
- 3.4. Click "Save Throttle Settings."

NOTE: Refer to your manufacturer's ESC manual for calibration instructions.

4 Go-to "Run Test" tab and click on "Start Test"

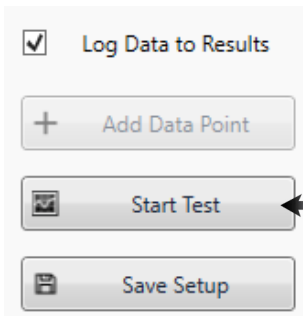

- 4.1. Once the test is complete. Go-to "Test Results" tab to review your test results.
- 4.2 You can save, print and export the test results.
- 4.3 Done!

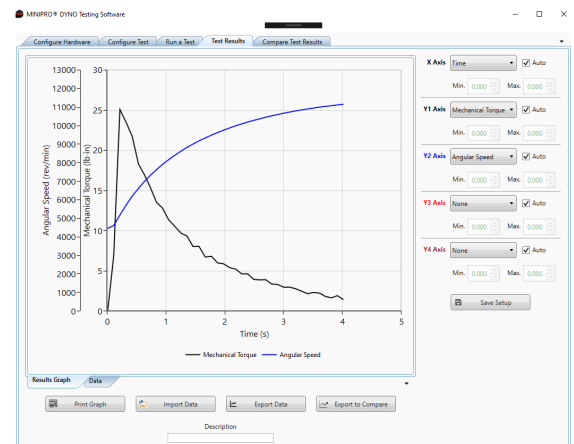

NOTE: You can cancel the Sequence Test at any time by clicking the "STOP" button or ESC Key.

PART LIST

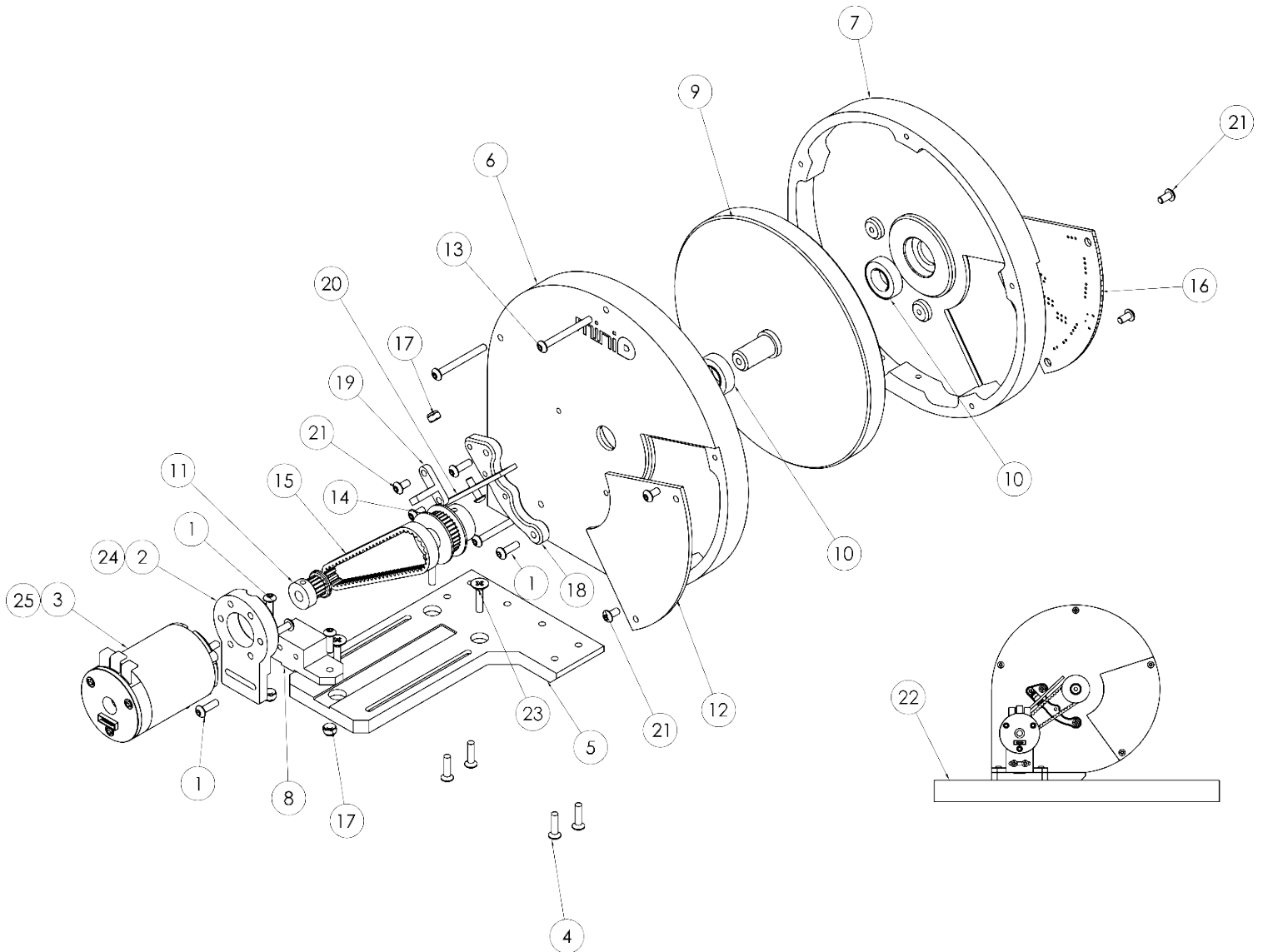

ITEM	QTY	PART NO.	DESCRIPTION	MATERIAL
1	9	0753340770187	ROUND HEAD SCREW - HEX M3X0.5 X 10	STAINLESS STEEL
2	1	0753340770064	540/550 MOTOR HOLDER	ALUMINUM 6061
3	1	NOT INCLUDED	540 OR 550 MOTOR	-
4	4	0753340770293	FLAT HEAD SCREW - HEX M3X0.5 X 12	STAINLESS STEEL
5	1	0753340770040	FLYWHEEL BASE	ALUMINUM 6061
6	1	0753340770002	FR. FLYWHEEL COVER	ALUMINUM 6061
7	1	0753340770019	RR. FLYWHEEL COVER	ALUMINUM 6061
8	1	0753340770057	SLIDER BLOCK	ALUMINUM 6061
9	1	0753340770026	FLYWHEEL, 124D ALU.	ALUMINUM
10	2	0753340770101	DG BEARING: 19X10X5	STEEL
11	1	0753340770262	PULLEY GT2: 16T 3.175ID	ALUMINUM 6061
12	1	0753340770095	CLEAR WINDOW COVER	ACRYLIC, CLEAR
13	3	0753340770170	ROUND HEAD SCREW - HEX M3X0.5 X 30	STAINLESS STEEL
14	1	0753340770125	PULLEY GT2: 32T 10ID	ALUMINUM 6061
15	1	0753340770132	BELT GT2: 78T 6MM	NYLON 6
16	1	0753340770149	MINID V1 ELECTRONIC BOARD	ABS PLASTIC
17	3	0753340770156	FLANGE NUT: M3 X0.5	STEEL
18	1	0753340770071	SHIELD HOLDER BRACKET	ALUMINUM 6061
19	1	0753340770088	SHIELD HOLDER	ALUMINUM 6061
20	1	0753340770163	BELT SHIELD	ACRYLIC, CLEAR
21	6	0753340770279	ROUND HEAD SCREW - HEX M3X0.5 X 6	STAINLESS STEEL
22	1	NOT INCLUDED	BASEBOARD: 10" X 10" X 3/4"	WOOD OR MDF BASE BOARD
23	3	0753340770293	FLAT HEAD SCREW - PHILLIPS #8 X 3/4"	STAINLESS STEEL
24	1	0753340770033	OUTRUNNER MOTOR HOLDER	ALUMINUM 6061
25	1	NOT INCLUDED	OUTRUNNER MOTOR	-

miniPRO
ELECTRIC MOTOR DYNO

www.minipro.com

© 2023 miniPRO, LLC. All Rights Reserved.