

MINIPRO[®] H1 SENSOR

INSTALLATION GUIDE

REVISION 2.0

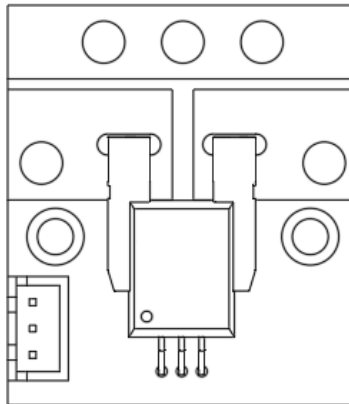

MINIPRO, LLC. 400 S Elliot Rd. Ste D-263, Chapel Hill, NC, 27514
Tech Assistance for Registered Owners (844) 517-4776, Fax: 844-517-3776
Email: info@miniprousa.com
Website: www.minipro.com

Copyright Notice
Copyright (C) 2024 MINIPRO, LLC. All Rights Reserved
MINIPRO® is a registered trademark of MINIPRO, LLC.

The software programs and user's manual are reserved by MINIPRO, LLC. and are intended for the use of the original owner only. Copying or duplicating these products except for the personal use of the original owner is a violation of U. S. Copyright Law and is hereby expressly forbidden.

Portions Copyright (C) Microsoft Corp. 1982-2024. All Rights Reserved
Windows is a registered trademark of Microsoft Corp.

SAFETY PRECAUTIONS

1. Make sure that dynamometers and motors under test are equipped with appropriate safety guards.
2. Make sure that all electronic products are earth grounded.
3. Do not exceed dynamometer and sensor specifications.



H1 SENSOR DIAGRAM

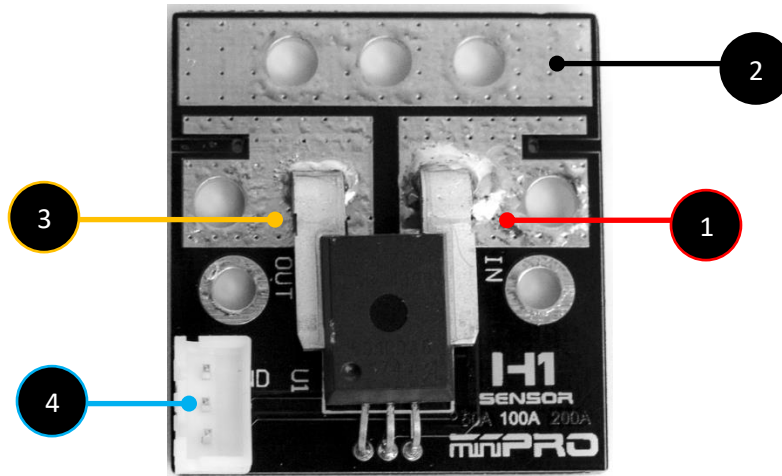

Figure 1: Sensor Diagram

ITEM	FUNCTION
1	Power IN: (+) side for the battery or power supply.
2	GROUND: (-) side for Battery, Power Supply and Motor Controller (ESC).
3	Power Out: (+) side for Motor Controller (ESC).
4	Sensor signal: Connection between Dyno and Sensor. The H1 Sensor might be equipped with a 3 pin or 4 Pin connector.

Sensor Specifications:

Sensor	Voltage (max)	Current (max)	Voltage Accuracy	Current Accuracy	UPC
50A/13V	13V	50A	+/- 0.05V	+/- 0.10A	0753340771016
100A/13V	13V	100A	+/- 0.05V	+/- 0.20A	0753340771023
150A/13V	13V	150A	+/- 0.05V	+/- 0.25A	0753340771030
200A/13V	13V	200A	+/- 0.05V	+/- 0.30A	0753340771047
50A/50V	50V	50A	+/- 0.2V	+/- 0.10A	0753340771153
100A/50V	50V	100A	+/- 0.2V	+/- 0.20A	0753340771160
150A/50V	50V	150A	+/- 0.2V	+/- 0.25A	0753340771177
200A/50V	50V	200A	+/- 0.2V	+/- 0.30A	0753340771184

Table 1: Sensor Specification



Warranty voided by exceeding sensor specifications.

DYNO BOARD WIRING DIAGRAM – V2.1 and older

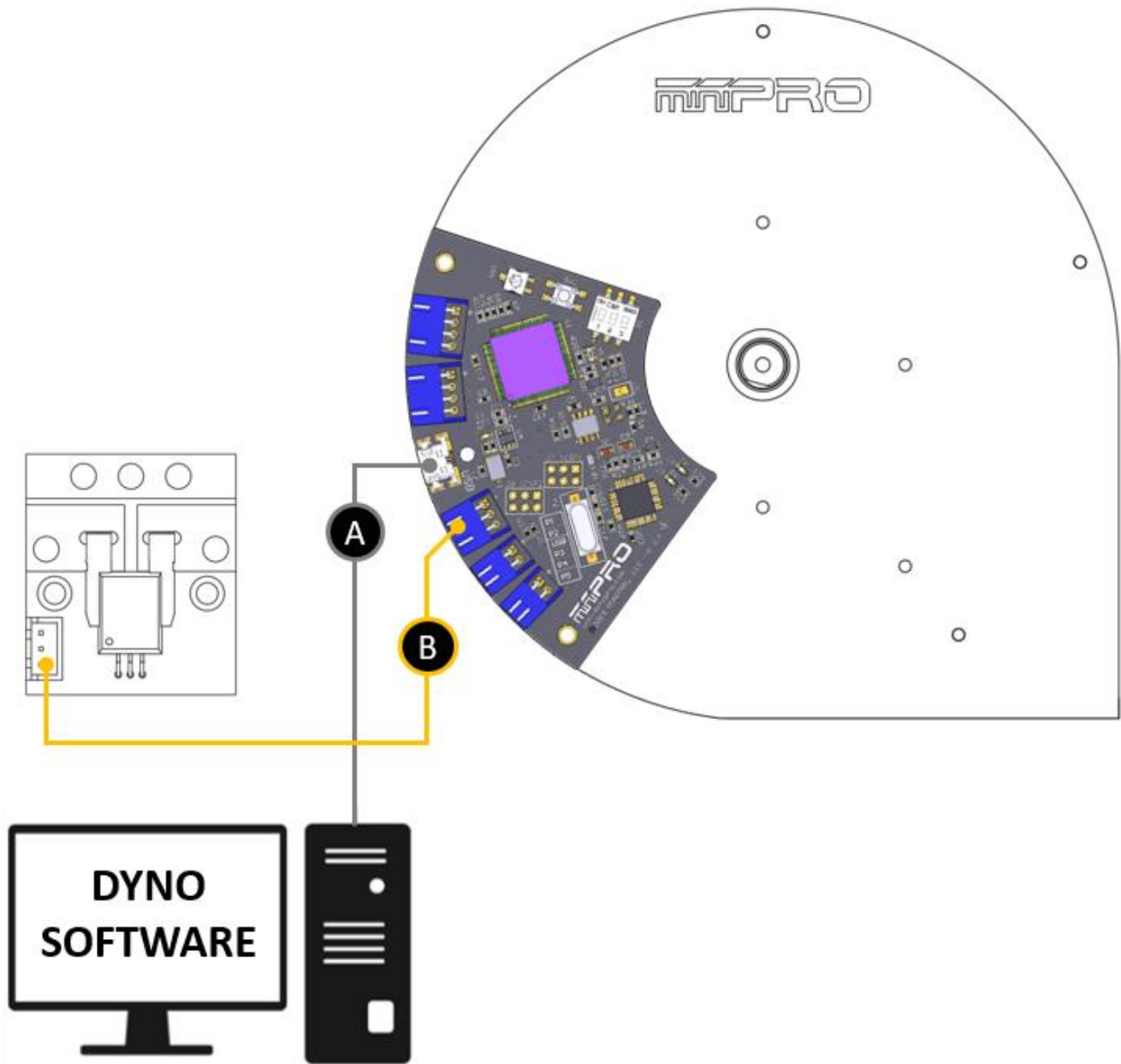

Figure 2: Dyno Controller Board V2.1 and older – Dyno to Board Wiring diagram

ITEM	FUNCTION
A	Micro USB Cable connects to a Windows PC.
B	3pin cable connects to H1 Sensor.



Warranty voided if it's not installed according to Figure 2.

DYNO BOARD WIRING DIAGRAM – V3.0

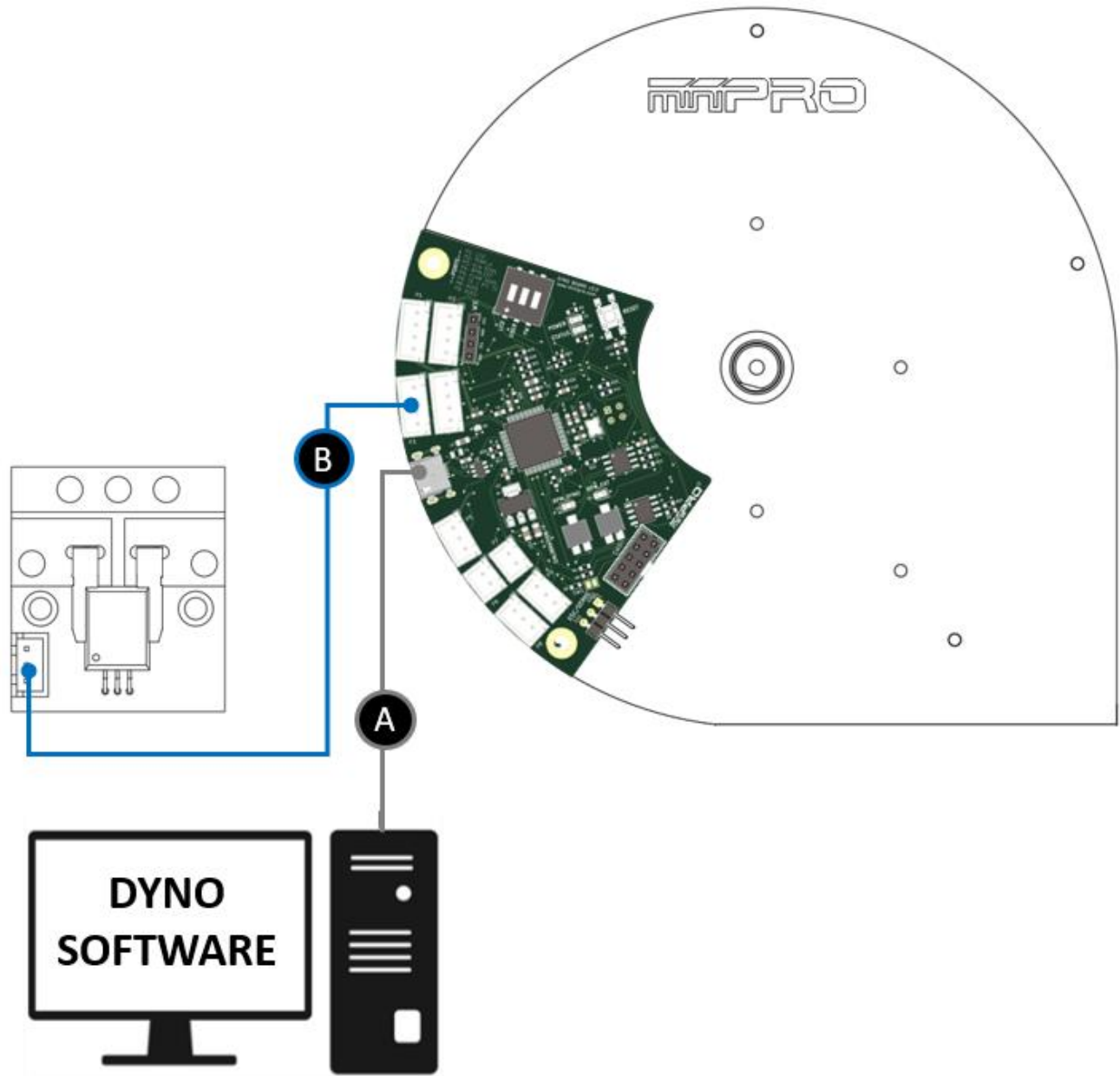

Figure 3: Dyno Controller Board V3.0 and later – Dyno to Board Wiring diagram

ITEM	FUNCTION
A	Micro USB Cable connects to a Windows PC.
B	The sensor cable connects to Dyno controller board. The H1 Sensor and Dyno controller board might be equipped with a 3 pin or 4 Pin connector.



Warranty voided if it's not installed according to Figure 3.

DYNO BOARD WIRING DIAGRAM – V3.1

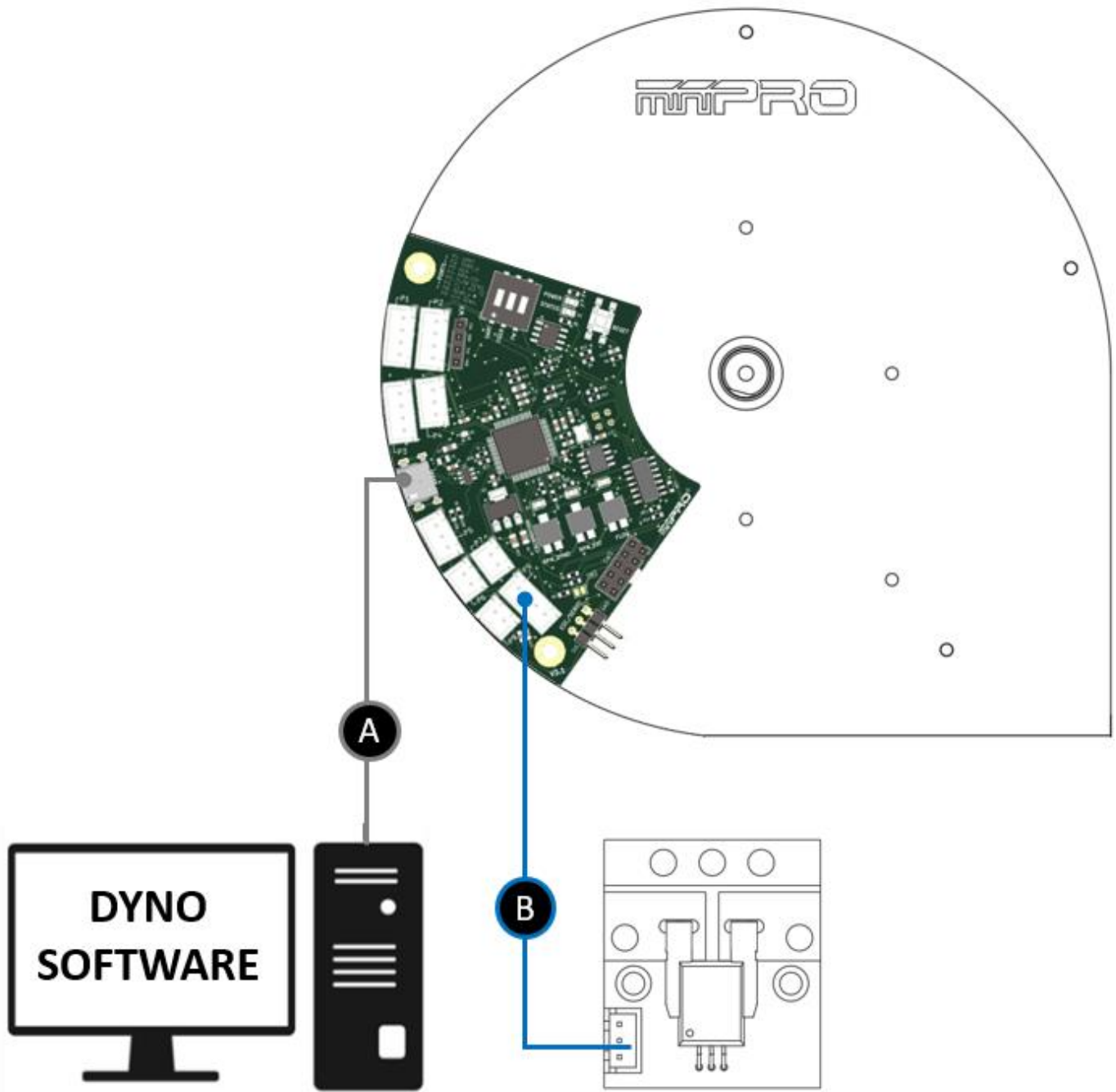

Figure 4: Dyno Controller Board V3.1 and later – Dyno to Board Wiring diagram

ITEM	FUNCTION
A	Micro USB Cable connects to a Windows PC.
B	The sensor cable connects to Dyno controller board. The H1 Sensor and Dyno controller board might be equipped with a 3 pin or 4 Pin connector.



Warranty voided if it's not installed according to Figure 4.

H1 SENSOR SOLDERING DIAGRAM – BRUSHED

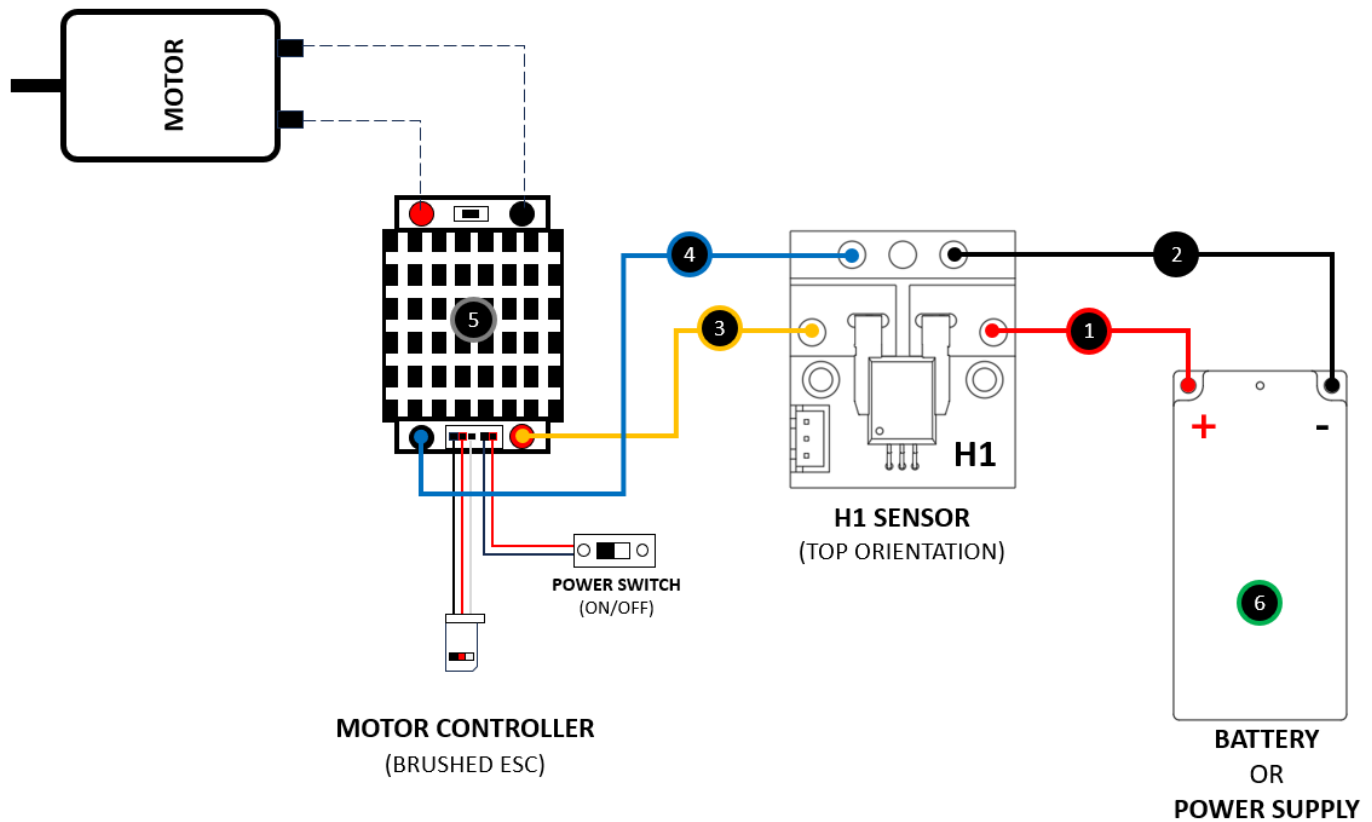

Figure 5: H1 Sensor Soldering Diagram for Brushed Motors

ITEM	FUNCTION
1	Connection between (+) Battery or Power Supply and (+) IN of the sensor
2	Connection between (-) Battery or Power Supply and (-) IN of the sensor
3	Connection between (+) OUT and (+) Power for Motor Controller (ESC). IMPORTANT: Check ESC manufacturer's manual for power connection information.
4	Connection between (-) OUT and (-) Power for Motor Controller (ESC). IMPORTANT: Check ESC manufacturer's manual for power connection information.
5	Brushed Motor Controller (ESC). IMPORTANT: Check ESC manufacturer's manual for proper installation between Motor and ESC.
6	Battery or ESC Connection. IMPORTANT: Do not exceed the sensor's voltage specifications.



Soldering Tutorial Video available in our YouTube channel:
<https://www.youtube.com/@miniprousa/videos>



Warranty voided if it's not installed according to Figure 5.

H1 SENSOR SOLDERING DIAGRAM – BRUSHLESS

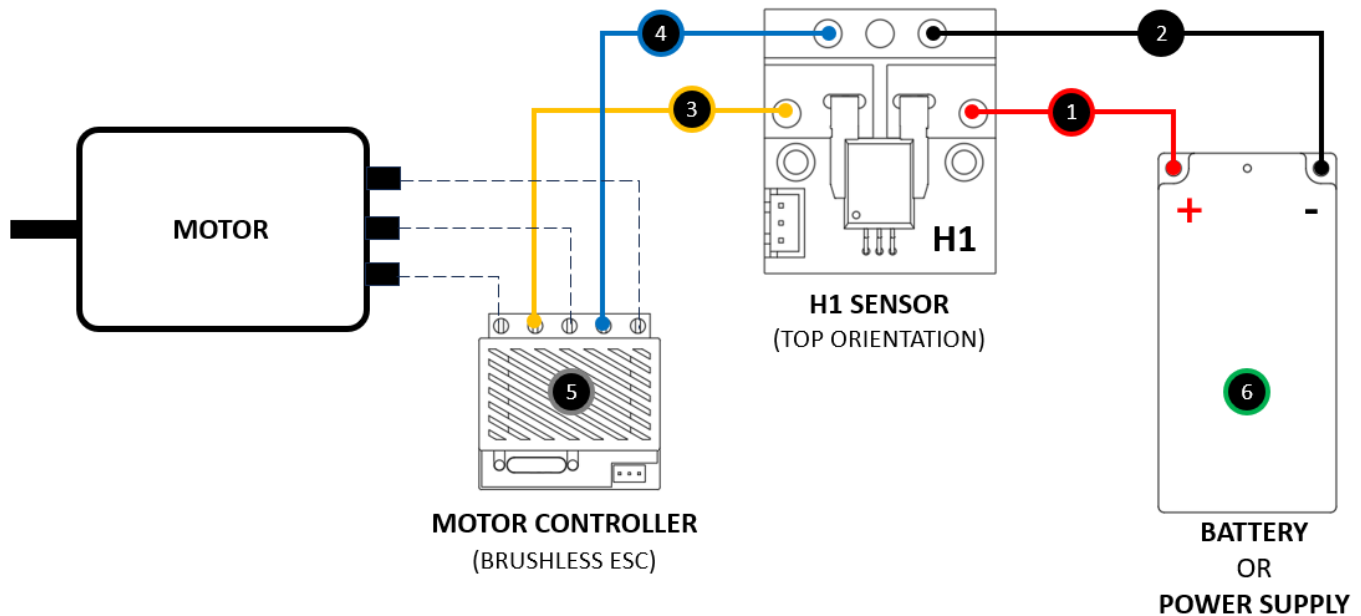

Figure 6: H1 Sensor Soldering Diagram for Brushless

ITEM	FUNCTION
1	Connection between (+) Battery or Power Supply and (+) IN of the sensor
2	Connection between (-) Battery or Power Supply and (-) IN of the sensor
3	Connection between (+) OUT and (+) Power for Motor Controller (ESC). IMPORTANT: Check ESC manufacturer's manual for power connection information.
4	Connection between (-) OUT and (-) Power for Motor Controller (ESC). IMPORTANT: Check ESC manufacturer's manual for power connection information.
5	Brushless Motor Controller (ESC). IMPORTANT: Check ESC manufacturer's manual for proper installation between Motor and ESC.
6	Battery or ESC Connection. IMPORTANT: Do not exceed the sensor's voltage specifications.



Soldering Tutorial Video available in our YouTube channel:
<https://www.youtube.com/@miniprousa/videos>



Warranty voided if it's not installed according to Figure 6.

SOFTWARE CONFIGURATION – V4.4 and older

INSTRUCTIONS:

1. Make sure the battery is connected to the sensor (see Figure 5 or 6) but the motor controller (ESC) is turned-off.
2. Open the MINIPRO Testing Software and push the Connect button to establish communication with the dyno.
3. Switch pin #3 or pin #8 to the Up (ON) position and push the Reset button (see Figure 7).
4. Select the Voltage and Current sensor from Voltage and Current Sensor drop-down option (see Figure 7).
5. Press the Save Settings button.
6. Switch pin #3 or pin #8 to the Down (OFF) position and close the setup window.
7. Push the Reset Button and Connect the dynamometer to the program and your configuration is complete.
8. **IMPORTANT:** To calibrate (reset) the current to zero, push the Reset button.

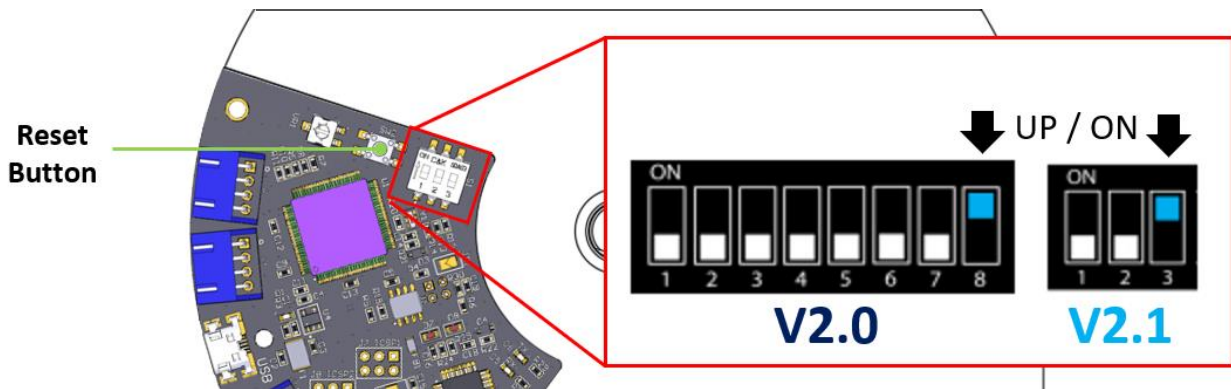

Figure 7: Setup Mode for Software V4.4 and older for Dyno boards V2.1 and older

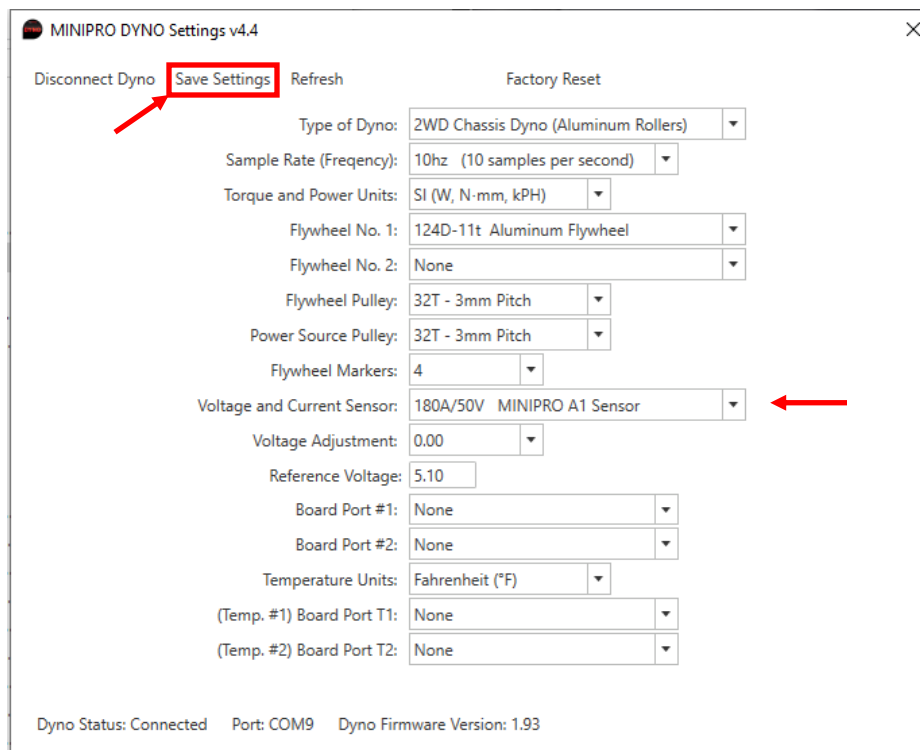

Figure 8: Settings Window for Software V4.4 and older

SOFTWARE CONFIGURATION – V5.0 and later

INSTRUCTIONS:

1. Make sure the battery is connected to the sensor (see Figure 5 or 6) but the motor controller (ESC) is turned-off.
2. Open the MINIPRO Testing Software and Connect the dynamometer to the program.
3. Go-to *Configure Hardware* -> *I/O Hobby Grade* tab.
4. Make sure that your sensor cable is connected to P3 or P9 (see Figure 3 and 4)
5. Select the Voltage and Current sensor from Port #3 or #9 drop-down option (see Figure 9).
6. Press the Apply Settings button.
7. **IMPORTANT:** To calibrate (reset) the sensor to zero, go-to *Configure Hardware* -> *Dynamometer Hardware* tab.
8. Press the Zero button next to Current SF text box (see Figure 10).
9. Press the Save Setup button, and your configuration is completed.

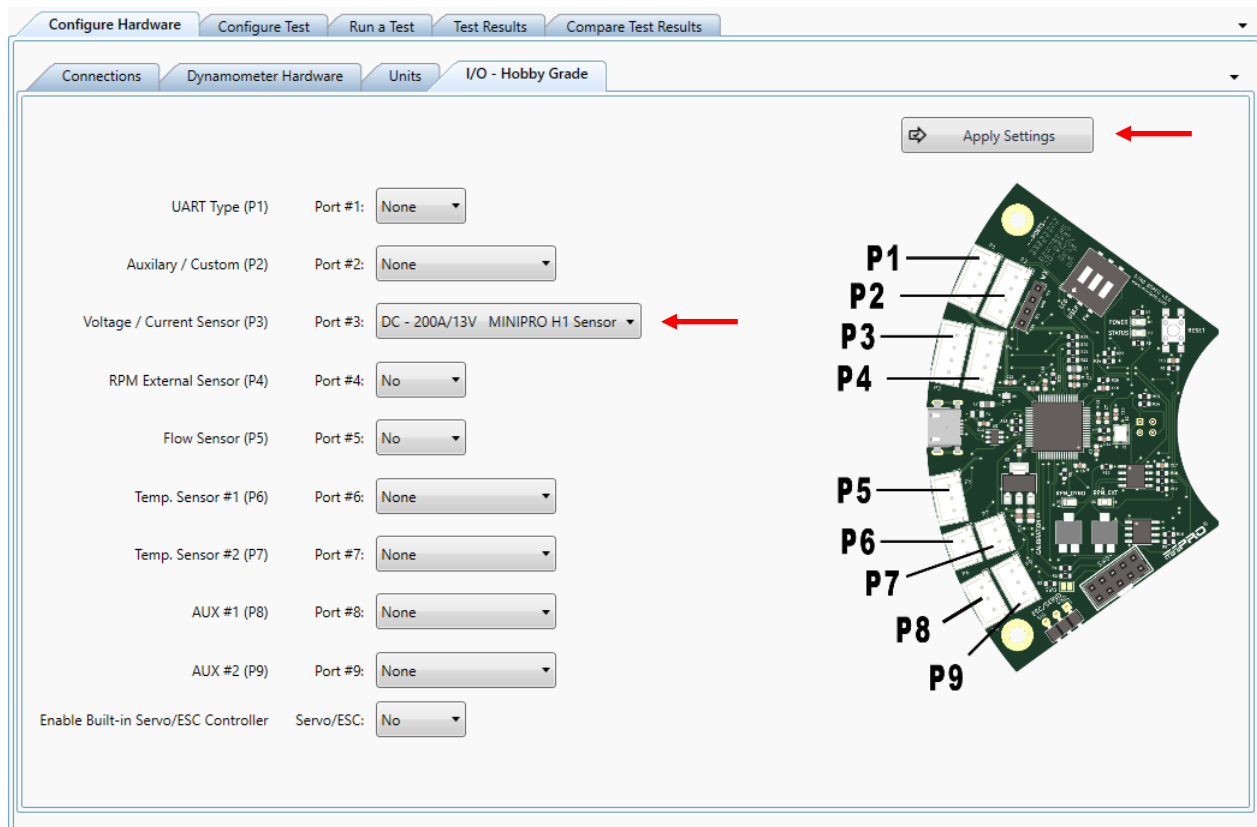

Figure 9: H1 Sensor - I/O Configuration

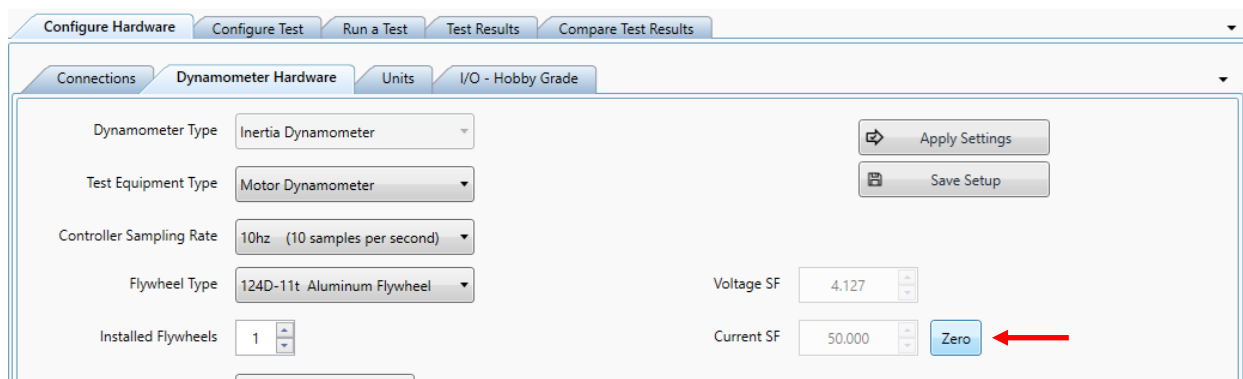

Figure 10: Current Sensor Calibration